

# Financial leadership for government

Petr Bouchal and Julian McCrae



**CIMA**

Chartered Institute of  
Management Accountants



# About the authors

**Julian McCrae** is the Director of Research at the **Institute for Government** and has worked there since July 2009. Prior to this, he was one of the Deputy Directors at the Prime Minister's Strategy Unit. His other experience in government includes two spells in the Treasury, and at the Department for Work and Pensions. Julian started his career at the Institute for Fiscal Studies, where he spent eight years.

**Petr Bouchal** is a Researcher at the **Institute for Government**. He joined in April 2012 and his work focuses on the Whitehall Monitor and on financial leadership in government. Petr holds an MPhil in Politics from the University of Oxford and a BA in International Relations and Economics from Tufts University in the United States. Previously, he worked on good governance at the Open Society Fund in Prague and provided research assistance to a University of Oxford project on parliamentary politics.

# Acknowledgements

This project was undertaken in partnership with Chartered Institute for Management Accountants (CIMA), who brought invaluable skills and expertise to the work. The authors would like to acknowledge the advice and support received from the many people who have helped make this report possible. In particular we would like to thank those who agreed to be interviewed. Finally thanks should go to colleagues at the Institute, particularly Tom Gash, who supported this work and the authors throughout. All views expressed, together with responsibility for any errors, are solely those of the authors.



# Contents

---

About the authors	3
Acknowledgments	3
Summary	6
1. Introduction	7
2. The functions of finance	8
3. Financial leadership in corporations	11
4. Financial leadership in Whitehall	16
5. International comparisons	22
6. Conclusion	28
Annex: approach and methodology	29

---

# Summary

The functions of finance are evolving. While control of money and budgets remains a core role, finance teams are increasingly taking on more strategic functions to support decision making and performance management. We are particularly interested in these evolving strategic functions as they relate most heavily to the concerns we raised about the supply and demand for management information in *Improving Decision Making in Whitehall*.

Comparing the activities of financial leadership in the private sector with Whitehall, it is clear that these strategic roles are often weaker at the very centre of government. In some areas, such as supporting performance management, these central leadership roles are relatively under-developed. These differences are reflected in the structure of financial leadership in Whitehall, which at a cross departmental level is more fragmented than that typically found in a private sector environment.

These weaknesses seem to be specific to the UK. Looking at some generally comparable centres of government in other countries, one striking feature is the relative weakness of the arrangements for performance management in the UK. It is also noticeable that the UK's Treasury does not take a leading responsibility for supporting performance management. In contrast, all the other organisations responsible for expenditure control play active roles in their respective countries' performance management systems.

It is also striking how weak the position of the leading finance professional in Whitehall is: a part-time post, acting as a first among equals with no formal input into key decision-making processes. In all other countries that we studied this is a senior, full-time post within a central organisation that is playing a clear role in the performance management system.

It seems clear that the UK needs to strengthen its performance management and financial leadership. Indeed, the UK has huge experience of running large, diversified organisations within its private sector. Drawing on this experience to strengthen the centre of government could be a truly world leading initiative. This should be considered in the summer as part of the Government's review and refresh of its civil service reform programme.

# 1. Introduction

Government is facing significant challenges in the wake of the financial crisis. It needs to preserve the value of public services while reducing costs and avoiding undue risks. However, there are long-standing and well documented limitations to Whitehall's ability to make fully informed decisions. This paper follows up the recent paper by the Institute and CIMA, *Improving Decision Making in Whitehall*, which focused on improving the use of management information. There we argued that the skills to develop the *supply* of management information lay primarily within the finance function. However, systemic improvements in the use of this information would only be unlocked by increasing the demand for management information from senior decision makers. These factors in turn highlighted for us the importance of financial leadership in improving performance management at the top of government departments.<sup>1</sup>

This paper builds on that analysis by taking a wider look at the functions of finance. It provides evidence on how these functions are structured within large corporate groups and in Whitehall. In particular it looks at how the role of central financial leadership varies within these different contexts. It further looks in detail at how performance management and financial leadership are structured within the national governments of various countries. By providing a structure for thinking about the role of financial leadership at the centre of large devolved organisations, it supports the Government's work to build a "much stronger corporate leadership model" as set out in its *Civil Service Reform Plan*.<sup>2</sup>

The analysis is based on a literature review of articles, manuals and reference texts on the functions of finance, accompanied by survey evidence on the roles played by financial leadership. This is complemented by a number of interviews with financial leaders and experts from several countries. See Annex A for further details.

The rest of this paper is structured as follows: Section 2 provides a simple typology of various functions finance plays within an organisation. Section 3 outlines the respective roles typically played by the centre and divisions of large corporate groups in undertaking each of these functions. Section 4 contrasts this with how these roles are currently split between the centre of Whitehall and line departments. Section 5 looks in more detail at how performance management and financial leadership are structured in other jurisdictions, comparing these to the structure in Whitehall. Section 6 concludes.

---

1 McCrae et al., *Improving Decision Making in Whitehall: Effective Use of Management Information*. Institute for Government, May 2012.

2 *Civil Service Reform Plan*, June 2012, p. 11.

## 2. The functions of finance

This section outlines a simple typology of the functions finance plays. It provides a means of outlining the key ways in which the finance function can add value to the wider activities of any entity. It is not intended to be an exhaustive list of all the things that a successful finance function might do in practice.

The typology breaks the functions of finance into three groups:

- traditional internal functions around the control of money and budgets
- evolving strategic functions that support management and decision making across the entity
- long-standing external relationship management functions.

### Money and budgets

Control of money and budgets is a core role of any finance function. There are three main elements to this.

**Budgeting cycle**<sup>3</sup>: The budgeting cycle is the primary means of translating organisational strategy into quantified plans that allocate resources across the entity. It has three interrelated parts:

- The planning round allocates resources, within clearly defined budgets, to strategic priorities. The assignment of responsibilities for managing these budgets is integral to this process.
- Between planning rounds, budgets and the associated responsibilities provide the basis for in-period performance management. Performance against budget, together with re-forecasting of expected outturns, provides basic information that should underpin performance conversations across the wider organisation.
- The use of outturn information to inform the planning round for the coming period completes the cycle.

The traditional function of finance is to design and coordinate this cycle, and to provide all the financial information used within it.

**Expenditure control**: The primary responsibilities of the finance function in this area fall into two categories.

- In its **control and authorisation responsibility**, finance holds sign-off authority on expenditure to ensure that cash is spent on purposes that are in concordance with the budget and other rules.
- Finance ensures that accurate records exist of what expenditure has been incurred. These records form the basis of internal and external reporting on financial issues.

---

3 See CIMA *Topic Gateway No. 27*. For a broad-ranging review of budgeting practices in the private and public sector, see the research report commissioned by the NAO to accompany its recent *Managing budgeting in Government* (NAO 2012).



**Internal audit:** The purpose of internal audit operations is to ensure that internal financial controls are effective and operate as intended.<sup>4</sup> This function is a cornerstone of ensuring propriety across the organisation.

## Strategic functions

Increasingly finance teams are taking on more strategic functions within the management of entities.<sup>5</sup>

**Supporting decision making:** The finance function may support the decision making of the wider management team in:

- appraising investments – assessing the financial aspects of investment proposals is a standard function of finance. This may support decisions on strategic investments as well as investment decisions within the budget process.
- cost management – a key function is developing an understanding of how inputs are related to outputs and outcomes. This allows costs to be more effectively controlled, permitting management to distinguish between short-term cost cuts and sustainable increases in productivity.
- managing risk<sup>6</sup> – finance will naturally be responsible for managing the purely financial risks. However entities in all sectors are expanding their capacity to manage a wider range of risks.<sup>7</sup> While finance may not be directly responsible for managing these wider risks, it will often play a central role in analysing them.

Any organisational strategy will draw heavily on these types of insights provided by the finance function. Indeed, in some organisations there may be a more direct relationship, with the strategic planning capability located within the finance function.

**Supporting performance management:** Financial information has always underpinned performance management through the budgeting cycle. More recently finance functions have expanded their role, providing insight through analysing financial and non-financial performance information from across the entity. To this end, the financial leadership will typically set the standards, metrics and reporting formats for management information. This information will underpin assessments of performance, flowing into both line management and other governance relationships throughout the entity.

## External relationships

Finally, finance has a major role in the external relationships of the organisation.

---

4 PwC 2012 *Internal Audit 2012 and PwC 2012 State of the Internal Audit Profession Study*.

5 See CIMA, *Finance Transformation: The Evolution to Value Creation*, CIMA, 2009.

6 CIMA *Topic Gateway No. 28*.

7 Margaret Woods, *Reporting and Managing Risk: A Look at Current Practice at Tesco, RBS, Local and Central Government*, CIMA, 2010.

**Preparation of accounts:** Financial accounts are probably the most important external reporting mechanism, affording those outside the entity with standardised information on its financial health. The accounts are prepared from information gathered during expenditure control activities. This information is aggregated and adjusted to produce the final accounts on the basis of appropriate charts of accounts.<sup>8</sup>

**Funding and treasury operations:** Finance is responsible for engagement with investors and creditors, providing information to them on the state of the entity, negotiating terms and providing funders with financial information. Treasury activities consist of managing and controlling cash that is not being used within normal operations, and investing this externally to gain an additional return.

**External compliance:** Compliance activities ensure that the financial management and reporting done by the entity is in line with legal requirements and that the management of tax complies with the appropriate legislation.

While this paper is concerned with all the functions outlined in this typology, we are particularly interested in the evolving strategic functions. These relate most heavily to the concerns we raised in *Improving Decision Making in Whitehall*.

---

8 For role of accounts in the development of finance, see case studies in IBM, *The New Value Integrator: Insights from the Global Chief Financial Officer Study*, 2010.

# 3. Financial leadership in corporations

Everything set out so far could apply to any organisation, large or small. In small businesses all the functions within the typology could be performed by a single management accountant. However, the largest entities can employ many hundreds of people to perform these functions. Typically they will be spread throughout the entity, following its organisational structure. So:

- a large private sector corporation will typically be split into a number of business divisions, with a headquarters that provides leadership, including financial leadership, to the group.
- Whitehall is split into 15 main line departments, with the central departments of the Treasury and the Cabinet Office looking across the whole. The Treasury, as the UK's finance ministry, has traditionally provided financial leadership in Whitehall.

Here we start by looking at how financial leadership typically plays out in a multi-divisional corporate setting, where the role of finance is most developed and where there is the greatest amount of survey data. In Section 4, we will compare this to the role of financial leadership in Whitehall.

We approach the role of financial leadership from two viewpoints. First we look at the activities actually undertaken by the central finance function. Then we look at the structural dimension – how the financial leadership is structured and relates to the wider management of the corporation.

## Activities

Certain activities have long been the preserve of the central financial leadership. In other areas, where the functions of finance have been evolving, financial leadership is taking on new roles and developing new skills.

## Money and budgets

The budgeting and cost control functions remain a central part of the financial leadership's role.

**Budgeting cycle**<sup>9</sup>: The budgeting cycle is a key activity performed by the executive team at group level. It is heavily supported by the group's financial leadership, who will usually have responsibility for **designing and running** the process. Businesses will vary in the degree to which they involve more junior layers of management in budgeting decisions.<sup>10</sup> One recent survey found that over 80% of the chief finance officers (CFOs) surveyed expected their leadership's interest in improving the budgeting activities of the finance function to increase in the next two years.<sup>11</sup>

---

9 CIMA, *Budgeting Practice and Organisational Structure*, 2010; PwC (2012) *CFO Budgeting Survey* <http://www.pwc.lu/en/finance-function-effectiveness/docs/pwc-cfo-survey-2012.pdf>

10 CIMA, *Budgeting Practice and Organisational Structure*, 2010.

11 PwC, *CFO Budgeting Survey*, 2012, p. 15, <http://www.pwc.lu/en/finance-function-effectiveness/docs/pwc-cfo-survey-2012.pdf>

**Expenditure control:** The responsibility for **setting the standards and systems** for authorising, processing and reporting financial transactions will rest with the group financial leadership. Available evidence suggests that in the changing business environment of the past five years, cost control has become more of a focus for group finance leaders.<sup>12</sup> The actual controls themselves will be performed at both group and division level. The exact degree to which expenditure control is centralised will vary from case to case. The financial leadership is most likely to **exercise direct controls** around things like major projects, or on cross-cutting areas of spend such as common IT infrastructure.

**Internal audit:** is generally performed at the division level. The group finance team will generally **support the group internal audit** function and the board audit committee decisions, though there will not always be a direct reporting line to the CFO.<sup>13</sup>

## Strategic functions

As the strategic functions of finance have been growing in importance there has been a corresponding evolution in the role of the financial leadership.

**Supporting decision making:** The CFO role is gradually broadening to include a range of responsibilities not entirely captured by the title 'chief financial officer'.<sup>14</sup> Almost 80% of respondents in a 2011 survey agreed that the primary role of the CFO is "about being a leader of the entire organisation rather than just being the head of the finance function".<sup>15</sup>

- Almost 90% of CFOs see themselves as being **centrally involved in cost management** across their businesses. Indeed, 44% describe themselves as decision makers, rather than advisers, in this area. This is also the area whose priority has risen most significantly for CFOs over the last three years.
- Risk management is a very close second in terms of rising importance.<sup>16</sup> In total, 83% of CFOs say they are **centrally involved in managing enterprise-wide risk**, either as an adviser or a decision maker.<sup>17</sup>
- Investment appraisal is another key decision support activity. The central financial leadership is at the heart of **strategic investment decisions at the group level**. Central finance can also support divisions, in a business partnering role, in refining their investment proposals as part of the budget process.

**Supporting performance management:** The measurement and monitoring of business performance was seen as a critical, cross-business role by 85% of CFOs in a 2010 survey – up from

---

12 Ernst & Young, *Financial Management Web Survey – Respondent Results*, 2006.

13 See e.g. <http://www.carlsberggroup.com/Company/Governance/Pages/InternalAudit.aspx> and [http://www.ubs.com/global/en/about\\_ubs/corporate\\_governance/audit/internal\\_audit.html](http://www.ubs.com/global/en/about_ubs/corporate_governance/audit/internal_audit.html). Accessed 15th December 2012

14 Ernst & Young, *Finance Forte*, 2011, p.7.

15 Ibid., p.10.

16 Ernst & Young, *The DNA of the CFO*, 2012, p.11; also IBM, *The Value Integrator*, 2010, p.15.

17 IBM, *The New Value Integrator*, 2010, p.13.

69% five years earlier. Alongside this, nearly 90% of CFOs see themselves as either advisers or decision makers on the selection of key performance indicators.<sup>18</sup> Responsibility for **generating and using enterprise-wide information** now generally rests with the group finance leadership, and this is an area where the role of group finance is becoming more important.<sup>19</sup> Evidence suggests that the more strongly finance is involved in such activities, the more likely the business is to be successful on a range of financial measures.<sup>20</sup>

## External relationships

Many of the external facing roles of finance are performed almost exclusively at the centre of the organisation. However, the degree to which these are the primary concern of the financial leadership varies.

**Preparation of accounts:** It is typically the role of the group financial controller to **ensure the preparation** of timely and accurate group accounts. This is part of the controller's responsibility for periodic financial reporting.<sup>21</sup>

**Funding and treasury operations:** These functions typically report to the CFO<sup>22</sup> and are **directly performed** at group level, since that is where they can add greatest value by integrating information from across the business. Nevertheless, these functions are perceived as technical in nature, with relatively little direct involvement by the CFO.<sup>23</sup>

**External compliance:** External compliance is generally the **responsibility of the CFO**, as it falls under the broader umbrella of corporate governance and enterprise risk. Decisions and responsibility lie at the group level, often with significant board involvement.<sup>24</sup>

Overall there is a move away from transactional and control activities toward greater focus on decision support. There are also clear aspirations to continue this shift, allowing finance to add more value to the business.<sup>25</sup>

---

18 IBM, *The New Value Integrators*, 2010, p.13.

19 Ibid., p.14.

20 Ibid.

21 See e.g. Ernst & Young, *The Changing Role of the Financial Controller*, 2008.

22 Ernst & Young (2008) *What's Next for the CFO? Where Expectations Meet Reality*; IBM, *Balancing Risk and Performance with an Integrated Finance Organisation*, IBM, 2008.

23 CIMA, *Finance Transformation: The Evolution to Value Creation*, 2010; Deutsche Bank et al., *CFO Views on the Importance and Execution of the Finance Function*, 2006; IBM, *CFO Survey: Current State and Future Direction*, 2003.

24 IBM, *CFO Survey*, 2003; Ernst & Young, *What's next for the CFO? Where Ambition Meets Reality*, 2008, CIMA Gateway Introductions.

25 IBM, *The New Value Integrators*, 2010, p.41, p.29.

## Structures

Having looked at the activities undertaken by the central financial leadership, we now examine the structural dimension – how the financial leadership is structured and relates to the wider management of the corporation. The relationship of financial leadership to the wider group management typically means the CFO is:<sup>26</sup>

- a member of the executive team, often acting as the chief executive officer's (CEO's) second in command, who is responsible for the performance of divisions and their managing directors
- responsible for the quality of financial management systems and processes across the group
- responsible for ensuring that a standard set of data (financial and non-financial) on the performance of divisions is available to the executive team and board.

In terms of providing leadership within the finance function, the management structure will often involve:

- a group finance team which supports the CFO and executes the central finance functions
- some kind of formal relationship, typically a “dotted line” between divisional finance directors (FDs) and the CFO, which helps ensure reliable information for reporting and the performance management of divisions<sup>27</sup>
- the CFO assessing the performance of divisional finance directors and may advise on their appointment.

A stylised group finance structure, reflecting these features, is depicted in Figure 1.

**Figure 1: Stylised structure of financial leadership in a group business**

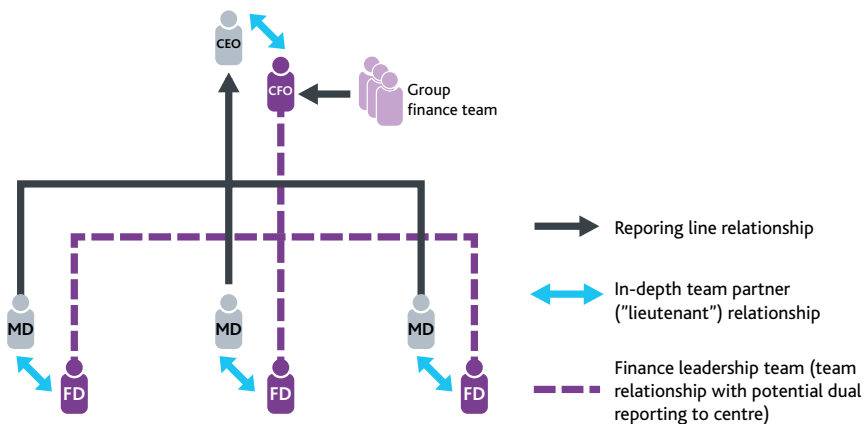

26 Recent surveys of CFOs show that the focus of the CFO role is moving away from “chief accountant” towards adding value by providing advice to the CEO on performance across the entire business. See for instance IBM, *The New Value Integrator*, 2010.

27 See CIMA, *Fact or Fiction? The Independent Business Partner*, CIMA: October 2012, p. 5; also CIMA, *From Ledgers to Leadership: a Journey Through the Finance Function – 2012 Update*. CIMA, 2012.

This set of responsibilities and relationships helps facilitate the activities of financial leadership. It provides the leadership with the right tools to ensure that divisions across the group are exercising appropriate controls and are capable of producing reliable financial and performance information.

# 4. Financial leadership in Whitehall

This section compares the activities and structures of financial leadership in Whitehall with those typically found in large corporate organisations. In some cases there are great similarities while in others there are striking differences.

## Similarities

We start with the similarities.

**Expenditure control:** In Whitehall, the oversight of expenditure control lies with the Treasury. In particular cash management is a strength of the centre of government, with the Treasury enforcing strict spending limits on departments. This is reflected in correspondingly strong spending controls at departmental level.<sup>28</sup> More recently, some specialised direct expenditure control roles have been emerging in the Cabinet Office, with regard to areas like IT spending or major projects.

**Funding and treasury operations:** The Treasury, through the Debt Management Office (DMO), plays a similar role in funding and treasury activities as a group finance function would in a private sector setting. Funding activities – specifically borrowing on the bond markets – are managed almost exclusively by the Treasury, with other central government organisations borrowing on their own account only in rare individual cases. Likewise, the Treasury, together with the DMO, normally manages the government’s cash balances.<sup>29</sup>

## Differences

There are, however, a range of internal management areas where Whitehall operates quite differently to the typical corporate organisation.

**Budgeting cycle:** The budgeting process in Whitehall differs significantly from that seen in private sector groups. The centre of government’s role in planning and budgeting is largely limited to periodic spending reviews, where it exercises the normal financial leadership role of designing and running the process. These reviews vary in how they are structured, including in terms of the time periods covered and the information used. Departments are where most detailed planning and budgeting occurs. The departmental planning and budgeting cycles are annual, but the way they are executed varies from department to department. The Treasury plays a limited role in these departmental planning rounds. There are a number of reasons that may explain this relatively ad hoc approach to budgeting.

---

28 See The Treasury, *Improving Spending Control*, HMT, April 2012.

29 See The Debt Management Office’s Exchequer cash management remit for 2011-12, [http://www.hm-treasury.gov.uk/d/dmo\\_exchequer\\_cmr\\_2011\\_12.pdf](http://www.hm-treasury.gov.uk/d/dmo_exchequer_cmr_2011_12.pdf), accessed on 10 December 2012.



- First, the political aspect of expenditure allocation is a key determinant of how budgeting in government occurs. Many top-level allocation decisions are driven by political considerations and are subject to political negotiation across the cabinet. It is harder to develop consistently strong approaches to making decisions about allocating spending in these circumstances.
- Second, the Treasury's focus on controlling spending determines its focus in the budgeting process. The immediate concerns of the spending review determine the quality and scope of information that departments provide to the Treasury as part of the budgeting process. This varies significantly from spending review to spending review.
- Third, there are major variations in the scale and focus of Whitehall departments. Improvements in budgeting and planning practices are usually driven from within, and are bespoke to, individual departments.

Whatever the reasons, the limitations of planning and budgeting have some important consequences, such as limiting opportunities for identifying cross-Whitehall savings. It also means that responsibilities for budgets are never systematically assigned and cascaded across Whitehall.

**Supporting decision making:** Support for decision making is more limited within the centre of Whitehall. In a recent report, the NAO noted that “central government’s key guidance provides for strong budgetary control, but is weaker in supporting informed decisions and challenge as well as how budgeting integrates with other key processes”.<sup>30</sup>

- Option appraisal in Whitehall is typically part of the standard policy process, as it will usually involve a ministerial decision. The exact nature of the decision making process will vary.<sup>31</sup> The Treasury will be involved in most processes, though usually with an expenditure control focus.
- On cost management, the Treasury typically acts as a reviewer of other department’s work. Its interest is usually focused around requests for extra resources, or as part of the ad hoc spending reviews. There is relatively little systematic pressure on departments to enhance their understanding of their own cost dynamics, and no formal processes to enhance understanding of the cross-departmental cost dynamics.
- It is difficult to pin down exactly where individual parts of risk management take place, but it is clear that, at least on the official side, there is no ‘group-level’ view of the overall risk held by departments. Given the role of political leadership and the presence of political risk, and given the diversity of issues dealt with by individual departments, it is possible to argue that the need for whole-of-government risk management is limited. But there may be added value in standardising and potentially centralising some common issues. The management of currency risk is an obvious example.<sup>32</sup>

---

30 NAO, *Managing Budgeting in Government*, 2012, p, 18.

31 See the Institute’s work on *Better Policy Making* for a detailed look at policy making processes in Whitehall (available at <http://www.instituteforgovernment.org.uk/our-work/better-policy-making>).

32 The Treasury has rejected a recommendation by the Public Accounts Committee (PAC) to take a stronger role in managing currency risk. See 48th report (2010-12 session) by PAC and Treasury Minutes from December 2011.

**Supporting performance management:** The appraisal of permanent secretaries in line departments lies with the Head of the Civil Service. However, Whitehall's finance ministry plays little role in supporting the Head of the Civil Service. It is not responsible for generating any cross-government information to underpin performance management. This reflects the Treasury's view that the performance of departments is a matter for departments themselves.<sup>33</sup>

There is no other point at which either financial or non-financial information is brought together to form a clear analytical view of the performance of departments. There are some existing initiatives that have had limited success.

- The Cabinet Office's Business Plans focus strongly on politically driven structural reform and contain little information about the performance of "business as usual" activities in departments.<sup>34</sup>
- The first version of Quarterly Data Summaries (QDS) has suffered from data quality issues – since they are not used for making decisions, departments have not seen reasons to provide data of the required quality and standards. Recent work is seeking to resolve these issues.
- An Implementation Unit has recently been created within the Cabinet Office, which has picked up some of the roles previous undertaken by the Prime Minister's Delivery Unit (PMDU), which was itself abolished in 2010.

**Internal audit:** Internal audit is a responsibility performed by individual departments, with the Treasury taking a lead in setting the policy and providing guidance. At departmental level, audit committees of departmental boards provide oversight, but there is no equivalent committee at the centre of government.<sup>35</sup> The Treasury is currently finalising a programme of transformation of the internal audit function across government. This makes the role of the centre significantly weaker than the role of group internal audit in the private sector. In 2010 the Treasury found that only 60% of heads of internal audit see it as a standard setter.<sup>36</sup>

**Preparation of accounts:** Accounts have traditionally been prepared at departmental level. The Treasury sets the reporting policy and provides guidance, but it does not yet provide a common chart of accounts. While OSCAR, the Treasury's new expenditure reporting system, does impose a greater degree of consistency than the previous COINS system, the information provided remains to some extent bespoke to departments. However, the Treasury has gradually been taking on a larger role. Audited Whole of Government Accounts (WGA) were published for the second time in October 2012, covering the 2010-11 financial year. This year, the WGA were published 20 months after the end of the relevant financial year. Although that is an improvement on the previous year, it shows

---

33 Oral evidence to the Public Accounts Committee by Sir Nicholas Macpherson, the Treasury's Permanent Secretary, and Sharon White, Director General for Public Spending, 21 January 2013; see also e.g. Treasury Minutes from January 2013 in response to the 11th Report of the PAC (2012-13 session) on responsibility for cross-government savings.

34 See recent IfG *Whitehall Monitor* note on Departmental Business Plans by Justine Stephen, available at <http://www.instituteforgovernment.org.uk/our-work/more-effective-whitehall/whitehall-monitor>

35 NAO, *The effectiveness of internal audit in central government*, June 2012.

36 HM Treasury, *Internal Audit Strategic Improvement Plan: Research summary*, 2010.

that the accounts are not particularly timely for making decisions at the centre of government.<sup>37</sup>

**External compliance:** Compliance responsibilities lie mostly at departmental level, though the scope and nature of compliance requirements is different from those in the private sector. Departments must primarily ensure their compliance with reporting and accounting standards set by statute or by the Treasury, as well as with requirements of Parliament in the estimates process and within the operation of the scrutiny and accountability mechanisms.

Table 1 below summarises the areas of similarity and difference between the various activities undertaken at the centre of Whitehall compared to a typical large corporate organisation.

**Table 1: Comparative activities of Whitehall financial leadership**

Function	Activity	Central role	Detail
Money and budgets	Designing and running the budgeting process		Narrower Treasury role than typical corporate
	Setting the standards and systems for expenditure control		Similar Treasury role to typical corporate organisation
	Exercising direct expenditure control		Similar or stronger Treasury role than typical corporate organisation Emerging Cabinet Office role
	Supporting group internal audit		Transformation programme aims to strengthen role of Treasury
Strategic functions	Central role in cost management		Narrower Treasury role, emerging Cabinet Office role
	Central role in managing enterprise-wide risk		Significantly narrower Treasury role
	Supporting group-level strategic investment decisions		Narrower Treasury role than typical corporate organisation
	Generating and using enterprise-wide performance information		No Treasury role, emerging Cabinet Office role
External-facing	Financial reporting and preparation of accounts		Emerging Treasury role around WGA
	Performing funding and treasury operations		Similar Treasury role to typical corporate organisation
	Ensuring external compliance		Narrower Treasury role - generally around guidance

Similar or stronger role  
 Narrower role  
 Emerging role  
 Significantly narrower role

37 The Treasury itself notes this in the latest WGA (p. 72). Moreover, the WGA Statement of Internal Control states that HM Treasury is responsible for the process of producing the accounts, but not for the management of related risks across government.

## Structures

Currently financial leadership at the centre of government is significantly different from that which is common in analogous group structures. Financial management in Whitehall is currently structured around:

- a part-time, first among equals, head of the finance profession who chairs the Finance Leadership Group of departmental finance directors general
- the Treasury's expenditure control role, which is largely organised as a series of spending teams mirroring Whitehall's departmental structure. These teams ultimately report to the Treasury's Director General for Public Spending. Traditionally these teams have been staffed by generalists, with economics as the dominant skill set. More recently there has been a greater emphasis on bringing in financially qualified personnel.
- the Cabinet Office's series of controls in areas like IT and major projects, which have developed since 2010. These are structured around the different categories of spend, with the teams blending generalists and specialists in the particular areas. These teams ultimately report to the Cabinet Office's Chief Operating Officer for Government.

There is no professional finance support for the Head of the Civil Service. Figure 2 shows a stylised version of this structure.

**Figure 2: stylised structure of Whitehall's financial leadership**

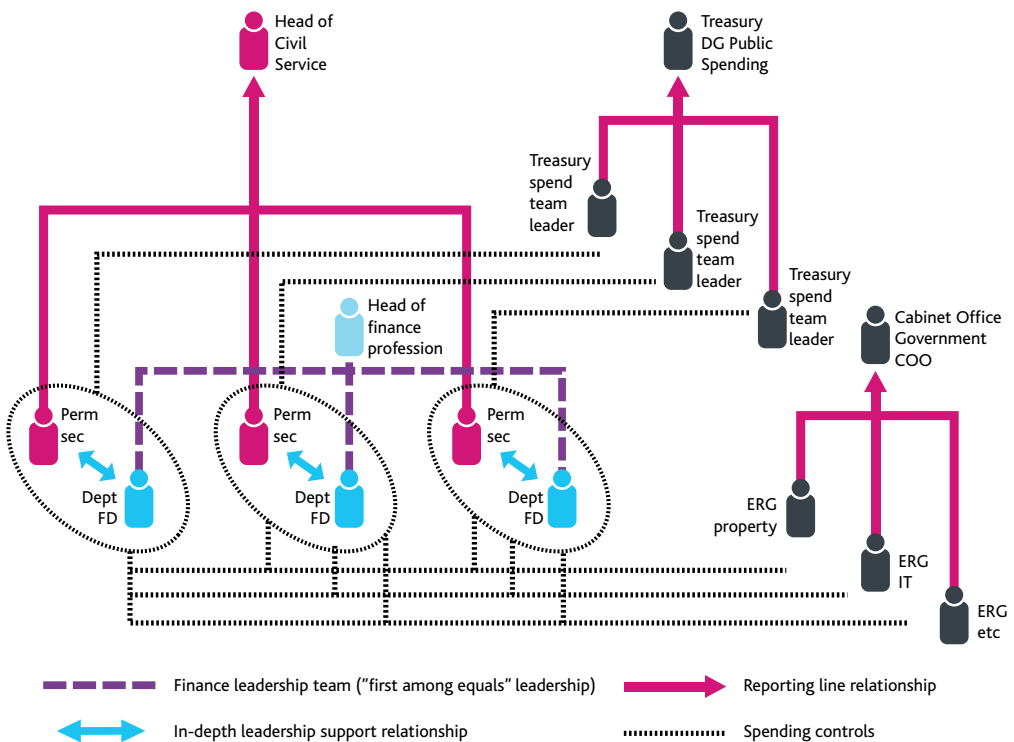

This structure, together with the nature of some of the processes, reflects the distribution of finance activities between departments and the centre of government. These activities are rather different from those found in a typical corporate group, with some central finance roles altogether absent. It is not obvious how Whitehall's current structure can best act as part of the "much stronger corporate leadership" envisaged in the Government's *Civil Service Reform Plan*.

## Developing Whitehall's financial leadership

In the wake of the financial crisis, the most important task facing the centre of Whitehall is the need to preserve the value of public services while reducing costs and avoiding undue risks. The evidence from the private sector shows that effective performance management in a large multi-divisional organisation is invariably underpinned by financial and non-financial information on performance. This information comes together at the centre of the organisation and is analysed and collated to be made useful to the CEO and the executive team. It is the finance capacity at the centre of the organisation which also sets the standards for building performance information and ensures that performance conversations are based on information that all sides recognise as correct and useful.

As this section shows, these roles are much less clearly defined at the centre of Whitehall. This suggests a potentially fruitful way to develop Whitehall's financial leadership. However, it is worth considering how applicable such models are to centres of government. Internationally, is the UK an outlier in having a relatively weak role for its financial leadership? Or is this a common feature of government across the globe? We consider this in the next section.

# 5. International comparisons

This section gives a sense of how the UK compares to some other countries in terms of how performance management is done, and how this relates to their financial leaderships. We examine the major Anglo-Saxon parliamentary systems – New Zealand, Australia and Canada. These are some of the most easily comparable centres of government to the UK. In addition, we also look at the US.

For each country, we look at:

- the types of cross-government systems in place to judge performance – in particular, we look at the role the finance ministry plays in these
- how these systems link to the appraisals of the top departmental officials
- how performance management is situated in relation to the other key aspects of Whitehall's financial leadership, namely expenditure control and the planning cycle.

We also examine how the financial leadership is itself structured. We focus on the post of the top financial professional in government. Is this post full-time or part-time? Who does it report to? Where is it based institutionally? What relationship does it have to finance directors in departments?

Throughout this section we compare activities and structures, rather than effectiveness.<sup>38</sup> The aim is simply to investigate whether Whitehall's financial leadership looks similar to that found in some of the more comparable centres of government.

## New Zealand

### The institutional landscape

In New Zealand the Treasury fulfils both the finance ministry and the economics ministry roles. Responsibility for policy delivery and outcomes is with the Department of the Prime Minister and Cabinet. The State Services Commissioner, supported by the State Services Commission, appoints, employs and reviews the performance of agency chief executives (the closest equivalent in New Zealand to the UK's permanent secretaries). The stated intention is to improve cooperation between the three central agencies to create a stronger corporate centre of government.

### Finance ministry roles

The New Zealand Treasury is responsible for the state sector being fit for purpose. As part of this responsibility, it runs benchmarking exercises and contributes to the Performance Information Framework (PIF) reviews. The PIF assesses each agency's fitness for purpose in terms of its corporate functions and organisational capabilities, as well as its ability to deliver on its core business areas

---

38 For a closer look at accountability and performance management in Australia and New Zealand, see Paun and Harris, *Reforming Civil Service Accountability*. Institute for Government, 2012.

and to contribute to the delivery of government priorities.<sup>39</sup> The PIF is run in conjunction with the Department of the Prime Minister and Cabinet and the State Service Commission. The actual appraisal of the heads of department (chief executives in New Zealand) is done by the State Services Commissioner. This assessment is underpinned by information emerging from the PIF.

The New Zealand Treasury is also responsible for designing and running the budgeting cycle, and for setting the standards and systems used for expenditure control. These roles provide it with a powerful base from which to judge performance, and for that judgement to matter.

### Senior finance leader

The most senior finance professional in New Zealand is the Treasury's CFO and Chief Accountant (CFO/CA). This is a full-time role, based in the finance ministry. It reports directly to the Chief Executive of the Treasury. The role acts as the 'finance guru' to the finance community. Its holder may advise agencies on the appointment of their CFOs.

However, the CFO/CA does not play the performance management support role that a private sector CFO would normally play. The CFO/CA is responsible for the preparation of New Zealand's WGA, which generally are produced more promptly and receive more attention than in the UK. These have allowed financial information to feed into decision-making. Over time, they have become the key source of information on things like Crown assets and liabilities, as well as providing the basic framework around which decision making is structured.

## Australia

### The institutional landscape

In Australia, the finance ministry is the Department of Finance. Other central agencies include the Treasury, which is the economics ministry and co-ordinates the budget process, the Department of the Prime Minister and Cabinet, and the Australian Public Service Commission. The Department of Prime Minister and Cabinet (DPMC) focuses on delivery and outcomes (similar to the way the PMDU operated in the UK) and Finance working on the economy and efficiency of the public service. The appraisal of Australia's top departmental officials, known as secretaries, is performed jointly by the Secretary of DPMC and by the Australian Public Services Commissioner.

### Finance ministry roles

The Department of Finance has responsibility for the good governance and efficiency of the public service as a whole. A significant amount of performance information comes together for the budget process, which allocates resources against outcomes. A validated set of performance indicators feeds into the secretaries' appraisal process.

The Australian Department of Finance is also responsible for setting the standards and systems used for expenditure control. The Financial Management Group within the department, consisting

---

39 For details on the Performance Improvement Framework, see <http://www.ssc.govt.nz/pif>

of around 300 FTEs, is responsible for the financial, reporting and spending frameworks, setting the standards and operating the systems for expenditure management and reporting, as well as some other central functions (risk management, procurement, major projects). However, the Treasury is responsible for designing and running the budgeting cycle. The Department of Finance feeds costings and value for money assessments into this process.

### Senior finance leader

The most senior finance professional in Australia is the deputy secretary in charge of the Financial Management Group. So this is again a full-time role, based in the finance ministry. It reports directly to the Secretary of the department. The nominal leader of the departmental CFO community also resides in the Department of Finance, though the post is relatively junior and acts as first among equals. CFO appointments rest exclusively with departmental heads.

### Recent developments

Current proposals mooted by the Department of Finance aim to strengthen the role of the department in setting the standards for performance management across the public service, in risk management, and in reporting, and to create a 'Finance as a Commonwealth CFO' by giving finance a stronger business analysis capability. This would allow the Department of Finance to strengthen oversight over the performance of individual agencies depending on the risk rating of the agency, arrived at by analysing financial and non-financial performance information. The same set of proposals also suggests setting out in legislation the role and responsibilities of CFOs in agencies.<sup>40</sup>

## Canada

### The institutional landscape

In Canada, the Treasury Board Secretariat (TBS) is responsible for aligning budgets, performance measures, and capability in departments. It supports the Treasury Board of Canada, which is a committee of Cabinet responsible for signing off spending allocations. Separately the Canadian Department of Finance is responsible for designing and running the budgeting cycle. The appraisal of top departmental officials, somewhat confusingly known as deputy ministers, lies with the Clerk of the Privy Council, who is simultaneously the secretary to the Cabinet, Deputy Minister to the Prime Minister, and Head of the Federal Public Service.

### Finance ministry roles

Individual policies and programmes have to be signed off by the Treasury Board before they can receive funding. This ensures that substantive business cases are in place when funding commences. However, somewhat surprisingly the TBS plays a limited role in monitoring performance against the measures it has agreed with departments.

---

40 Department of Finance and Deregulation, *Sharpening the Focus: A Framework for Improving Commonwealth Performance*, Commonwealth Financial Accountability Review Position Paper, November 2012, available at [cfa.finance.gov.au](http://cfa.finance.gov.au)



The TBS is also responsible for setting the standards and systems used for expenditure control. The Office of the Comptroller General (OCG) is responsible for government-wide internal audit, financial management and systems, and for developing the financial community in government. Additionally, the OCG is also responsible for the policy on acquired services – procurement and contracting. Since budgeting is controlled politically and decided in the Department of Finance, performance information collated in TBS may not typically feed into top-level budgeting decisions.

### **Senior finance leadership**

The most senior finance professional in Canada is the Comptroller General (CG), who heads the OCG. As such, this is a full-time role based in the department responsible for finance control. Departmental CFOs typically have a relationship with the CG so that they can raise concerns if they think there are issues with the management of the department that could affect financial integrity.

## **United States**

### **The institutional landscape**

The structure of the US system is determined by the separation of powers between the legislative and the executive branch. The Office of Management and Budget (OMB), as the main budget bureau, is located in the White House. The Treasury focuses on financial policy and performs some central transactional and system functions for other federal agencies.

### **Finance ministry responsibilities**

Both the budget cycle and expenditure control functions are located within the (OMB), which is part of the Executive Office of the President. Likewise, the performance management systems are set within the OMB.

The budgeting and spending process is run by the OMB but the work of finance leaders in agencies has a significant Congress-facing component, since Congress is the primary customer of performance reporting and makes decisions on individual lines of budgets.

The management side of OMB focuses on driving specific parts of the President's public service agenda (thus ensuring performance of stimulus funds) and also contains the Office of Federal Financial Management, which takes charge of improvement of financial management largely in the sense of systems and standards, propriety, accurate reporting, etc.

### **Senior finance leadership**

The most senior finance professional is the Financial Controller, who is responsible for financial reporting, the development of the financial community, and for parts of the efficiency agenda. This role is also located in the OMB and reports to the Director of the OMB. The Financial Controller also chairs the CFO Council, a statutory body composed of all federal agency finance directors.

## Lessons from the comparison

All the countries looked at have in place some system for aligning policy performance with budgets, and some form of assessment of performance at the centre. The degree to which these systems are used to make decisions about the allocation of resources and the assessment of leading officials varies. Table 2 summarises the responsibilities of the different organisations in the various countries.

**Table 2: Comparison: performance management at the centre of government**

	Assessment of managerial heads of departments	Supporting performance management	Expenditure control	Budgeting cycle
US	Political	OMB	OMB	OMB
Canada	PC Clerk	TBS	TBS	Finance
New Zealand	SSC	SSC/DPMC/Treasury	Treasury	Treasury
Australia	Sec DPMC & APSC	APSV/DPMC/Finance	Finance	Treasury
UK	Head of Civil Service	Cabinet Office	Treasury	Treasury

 Exists  Partial

The most striking feature of Table 2 is the relative weakness of the arrangements for performance management in the UK. The CO plays a partial role through the Business Plans and the Quarterly Data Summary (QDS). Permanent secretaries formally have appraisals with the Head of the Civil Service. But this is a much weaker relationship than that found in other countries – for instance in Canada one interviewee made clear “everyone works for the Clerk in this town”.

It is also noticeable that the Treasury takes no responsibility for supporting performance management. In contrast, all the other organisations responsible for expenditure control (the OMB, TBS, New Zealand Treasury and Australia’s Department of Finance) all play active roles in their respective countries’ performance management systems.

All of the countries looked at have seen significant efforts to strengthen the performance of the finance profession in government. Usually this has taken the form of raising the profile and responsibilities of the finance directors in departments, and setting up a post in government whose holder is the leader clearly responsible for leading the improvement in financial management in government. Generally this finance leader is also responsible for driving improvement of specific areas of financial management and for preparing the whole of government accounts (as in New Zealand). The institution in which the senior finance leader for government is situated generally also holds responsibility for related areas (procurement, asset management, major projects, etc.).

Table 3 sets out the roles of the various finance leaders in the different countries. Again it is striking how weak the UK position is. In all other countries this is a full-time post, and it reports to the head of an organisation that is playing a central role in the performance management system.

**Table 3: Cross-country comparison of role of finance leaders**

	<b>Title</b>	<b>Full-time</b>	<b>Location</b>	<b>Reports to</b>	<b>Input into decisions</b>	<b>Role in appointments</b>
New Zealand	Treasury CFO and Chief Accountant	✓	Treasury	CE of Treasury	Strong	Some
Canada	Comptroller General	✓	TBS (OFC)	Sec of TBS	Some	Some
US	Federal Financial Controller	✓	OMB (OFFM)	Head of OMB	Some	None
Australia	Deputy Secretary, Fin. Mngmt Group	✓	Dept of Finance	Sec of Finance	Some	None
UK	Head of Finance Profession	✗	Treasury	-	None	None

However, these financial leaders at the centre of government usually focus on financial management in the narrower sense of proper systems and reporting, and on the improvement of the capability of the financial management community. Only in Australia does the finance end of the spending department (the Financial Management Group of the Department of Finance and Deregulation) take on a more explicit role in driving efficiency in government.

In all of the countries there is a sense that the performance management framework is not ideal and that it could benefit from better integration with financial information, finance expertise, and with the budgeting and appropriations process.

# 6. Conclusions

Whitehall's financial leadership performs a more limited set of activities than those typically performed at the centre of a corporate group. In particular, the centre of Whitehall plays a weaker role in supporting the strategic functions of finance, such as performance management.

These weaknesses seem to be specific to the UK. Looking at other centres of government, the UK has relatively weak arrangements for performance management. It is also noticeable that the UK's Treasury does not take a leading responsibility for supporting performance management, in contrast to similar organisations in other countries.

This matters. The Institute's previous work on improving decision making has highlighted the importance of financial leadership and strengthened performance management at the top of government departments.<sup>41</sup> In the wake of the financial crisis, this would help Whitehall in the vital task of preserving the value of public services while reducing costs and avoiding undue risks.

So a potentially fruitful way to develop Whitehall's financial leadership would be to enhance its role in supporting performance management. The evidence from the private sector shows that effective performance management in large multi-divisional organisations is invariably underpinned by financial and non-financial information. This information comes together at the centre of the organisation, with the CFO and group finance function taking a leading role in ensuring it is analysed and collated for use by the executive team.

The UK's private sector has huge experience of running large, diversified organisations. Drawing on this experience to strengthen the centre of government has the potential to be a truly world leading initiative.

---

41 McCrae et al., *Improving Decision Making in Whitehall: Effective Use of Management Information*. Institute for Government, May 2012.

# Annex: approach and methodology

We have followed several approaches to draw together evidence on the role of financial leadership.

First, evidence on the roles and functions of finance in organisations and the activities finance performs was gathered from a range of manuals, reviews, and reference texts made available by professional bodies and professional services firms. The result is a stylised model of the finance function that can serve as a typology for understanding the range of roles that the finance function can play in the management of large organisations.

Second, we have used evidence from previous surveys of finance professionals, including CFOs, to provide an approximation of how these roles are performed in private sector organisations, and in particular to understand the distribution of responsibilities between finance leaders at the group level and at the division level, and the structures and relationships within which these roles are performed.

Third, we have conducted a small number of interviews with financial leaders inside the administrations of Australia, Canada, New Zealand, and the United States, as well as with several experts currently outside of government. The interviews provided insight into state of public financial management in these countries beyond what can be gleaned from publicly available documents.

Finally, the characterisation of financial management in Whitehall is based on insights gathered in the course of the various strands of research undertaken by the Institute for Government. This was complemented by comments and insights provided by current and former civil servants, non-executives and others.

The Institute for Government is here to act as a catalyst for better government

INSTITUTE  
FOR  
GOVERNMENT

The Institute for Government is an independent charity founded in 2008 to help make government more effective.

- We carry out research, look into the big governance challenges of the day and find ways to help government improve, re-think and sometimes see things differently.
- We offer unique insights and advice from experienced people who know what it's like to be inside government both in the UK and overseas.
- We provide inspirational learning and development for very senior policy makers.

We do this through seminars, workshops, talks or interesting connections that invigorate and provide fresh ideas.

We are placed where senior members of all parties and the Civil Service can discuss the challenges of making government work, and where they can seek and exchange practical insights from the leading thinkers, practitioners, public servants, academics and opinion formers.

Copies of this report are available alongside other research work at:

[www.instituteforgovernment.org.uk](http://www.instituteforgovernment.org.uk)

April 2013

© Institute for Government 2013

2 Carlton Gardens  
London  
SW1Y 5AA

Tel: +44 (0) 20 7747 0400

Fax: +44 (0) 20 7766 0700

Email: [enquiries@instituteforgovernment.org.uk](mailto:enquiries@instituteforgovernment.org.uk)

The Institute is a company limited by guarantee registered in England No. 6480524

Registered Charity No. 1123926